

OPERABLE WALLS
Panelfold®
Moduflex®
 SERIES 800
 Individual
 Panels

Model
 810 MD
 Multi-
 Directional

PRODUCT BRIEF

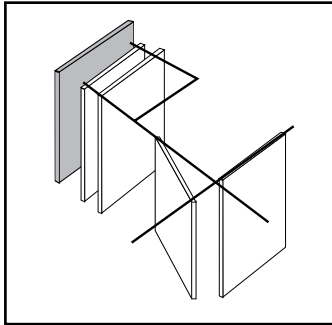

OPERATING FEATURES.
Moduflex Model 810MD
 Multi-directional, Individual panels, each supported with two glide discs or horizontal rotating ball-bearing carrier assemblies easily negotiate 90° 2,3 and 4 way track intersections. Each panel can be turned in any direction, anywhere along the track grid. Heights to 16' (4877).

ACOUSTICAL PERFORMANCE.
Moduflex Series 800 operable walls have attained ratings of STC 55, STC 53, STC 51, STC 49 and N.R.C. .80 (STC 51).

ings of STC 55, STC 53, STC 51, STC 49

PANEL FINISHES. A full range of vinyl, panel fabric, and wall carpet as well as Customer's Own Materials is offered.

U.L.® FIRE RATING. Series 800 walls may be specified with one hour rating.

TYPES OF CLOSURES

See pages 2,3 and 4 for details.

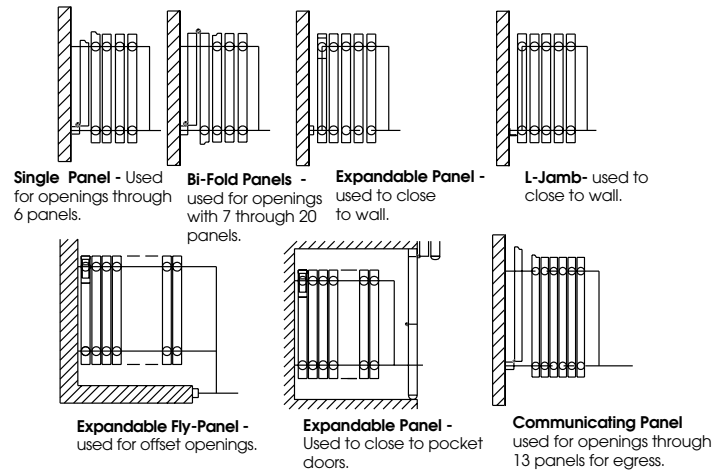

OPTIONS AND ACCESSORIES

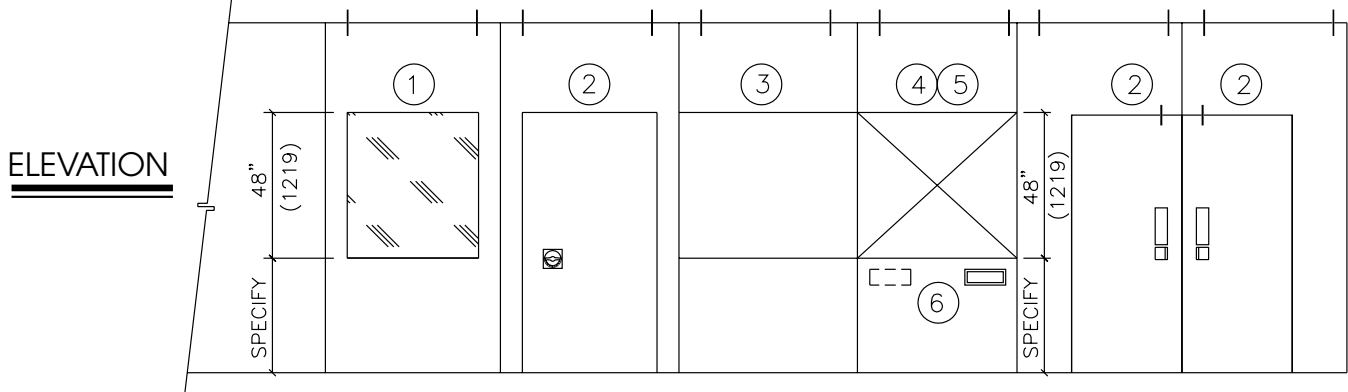

OPTIONS SPECIFICATIONS
 See page 8 for Product Specifications

- ① WINDOWS where indicated on the plans shall be nominally (specify: 48" (1219) high; or full panel height). Windows shall be (specify: factory glazed with 1/4" (6) clear acrylic; or unglazed, framed opening only). Windows shall be bronze trimmed.
- ② SINGLE PASS DOORS where indicated shall be nominally (specify: 3'0" (914); or 2'8" (813)) wide by (specify: 6'8" (2032); or 7'0" (2134)) high. Doors shall be manufactured of the same materials and thickness as the panels and be equipped with butt-type hinges and positive latches with drop cup and ring pulls. Double doors have roller latches. Options: deadbolt locks; self illuminated exit signs; hydraulic door closers; A.D.A. compliant friction roller latch with flush pulls.
- ③ TACKBOARDS where indicated shall be nominally (specify: 48" (1219)) high; or full panel height). Tackboards shall consist of 1/4" (6) cork surfaced with minimum 30oz per lineal yard Type II

- ④ CHALKBOARDS where indicated shall be nominally (specify: 48" (1219) high; or full panel height). Chalkboards shall be chalkable porcelain enameled steel (color to be selected from manufacturer's standards) and bronze trimmed.
- ⑤ MARKERBOARDS where indicated shall be nominally (specify: 48" (1219) high; or full panel height) and be of suitable non-porous surfaced porcelain enameled steel for application of write-on, wipe-off marker pens. Color of markerboards to be selected from manufacturer's standards and bronze trimmed.
- ⑥ RECESSED TRAY for storing chalk or marking pens and erasers shall be installed where indicated and shall be bronze color.

FURTHER INFORMATION. All dimensions shown in parentheses are millimeters. **Moduflex Series 800** operable walls have four inch thick welded steel panels for high performance demanding applications and are supplied with Manual™ clearance type bottom seal mechanisms that are actuated by a removable tool. Scale N.T.S.



Moduflex® SERIES 800
Individual Panels Model 810 MD

TYPES OF CLOSURES AND PANEL STACKING

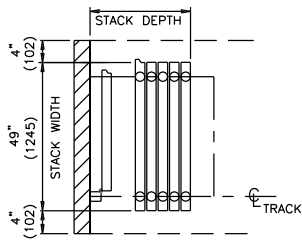

STACK

Single Panel

USED FOR OPENINGS THROUGH 6 PANELS

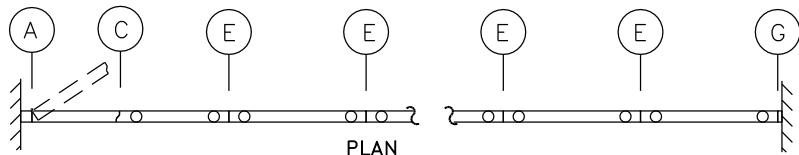

PLAN

STACK DEPTH = NO. PANELS X 4.625" (117) PLUS 3 1/2" (89)

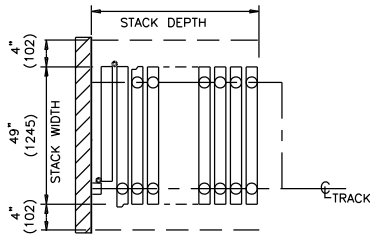

STACK

Bi-Fold Panels

USED FOR OPENINGS WITH 7 THROUGH 20 PANELS

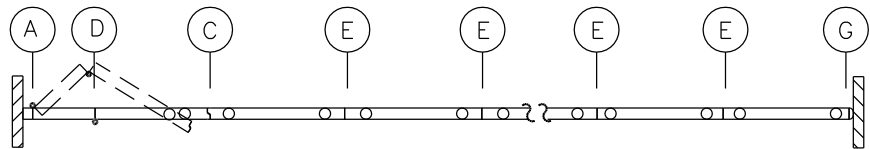

PLAN

STACK DEPTH = NO. PANELS X 4.625" (117) PLUS 3 1/2" (89)

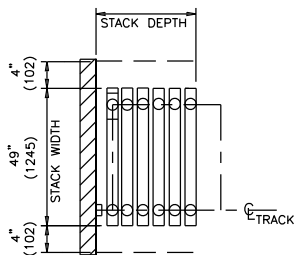

STACK

Expandable Panel

USED FOR OPENINGS THROUGH 6 PANELS

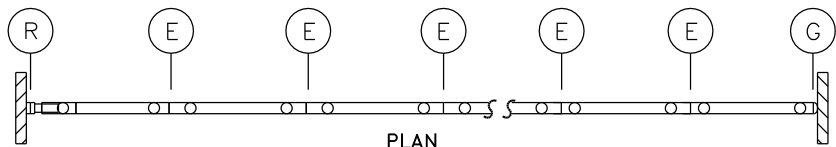

PLAN

STACK DEPTH = NO. PANELS X 4.625" (117) PLUS 3 1/2" (89)

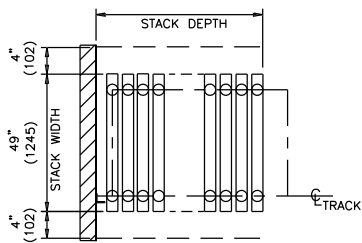

STACK

L-Jamb

USED FOR OPENINGS WITH 7 THROUGH 20 PANELS

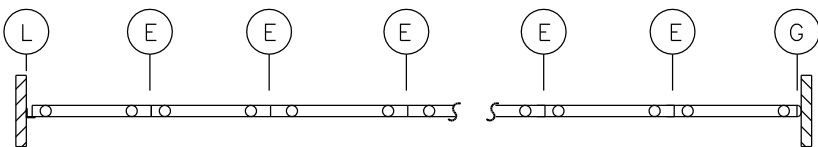

PLAN

STACK DEPTH = NO. PANELS X 4.625" (117) PLUS 3 1/2" (89)



Moduflex® SERIES 800
Individual Panels Model 810 MD

TYPES OF CLOSURES AND PANEL STACKING

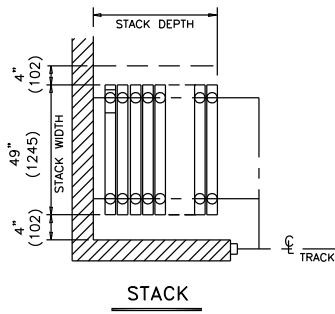

Expandable Panel

USED FOR OFF-SET OPENINGS

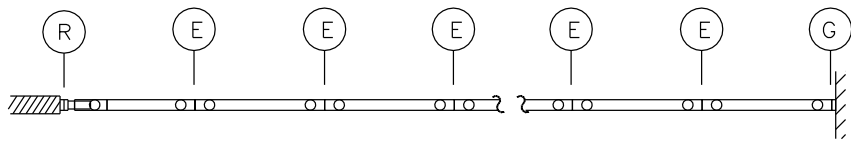

STACK DEPTH = NO. PANELS X 4.625" (117)

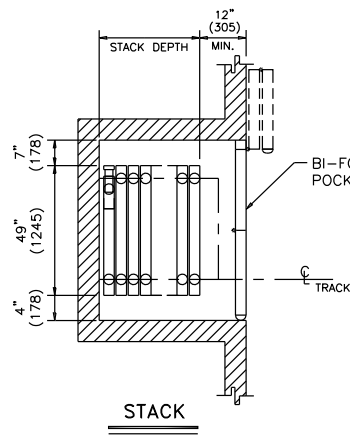

Expandable Panel

USED TO CLOSE TO POCKET DOOR

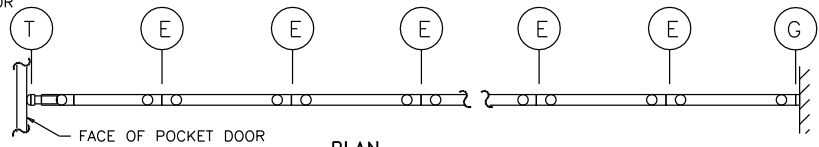

STACK DEPTH = NO. PANELS X 4.625" (117)

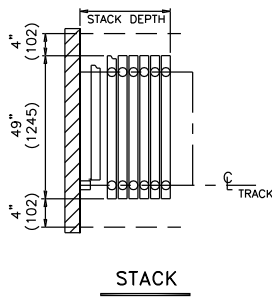

Communicating Panel

USED FOR OPENINGS THROUGH 13 PANELS

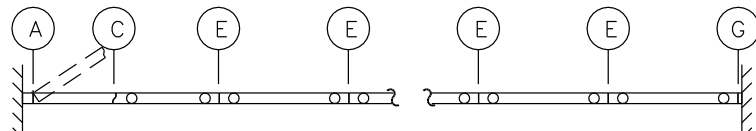

STACK DEPTH = NO. PANELS X 4.625" (117) PLUS 3 1/2" (89)



Moduflex SERIES 800

Individual Panels Model 810 MD

JAMBS AND PANEL INTERLOCKING DETAILS

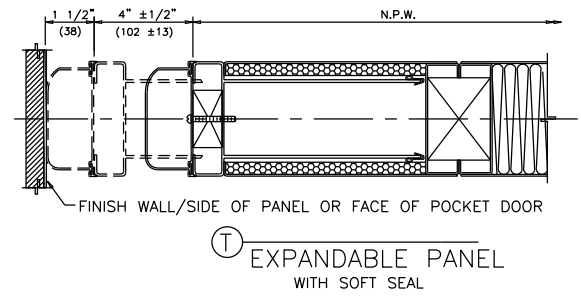
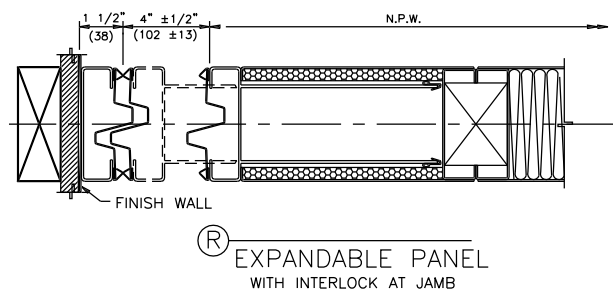
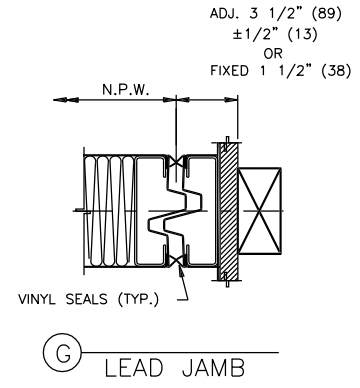
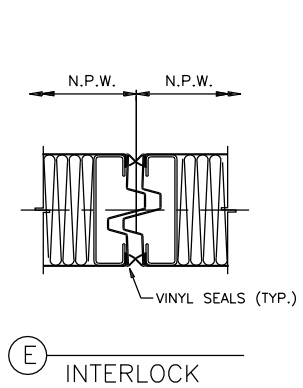
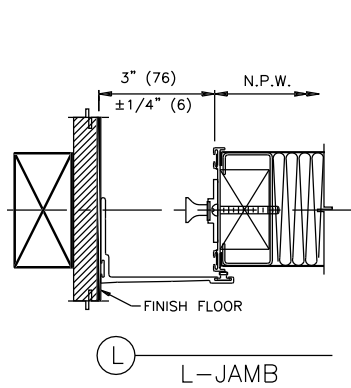
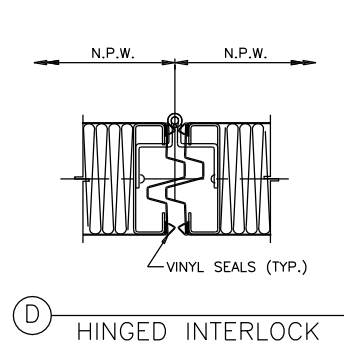
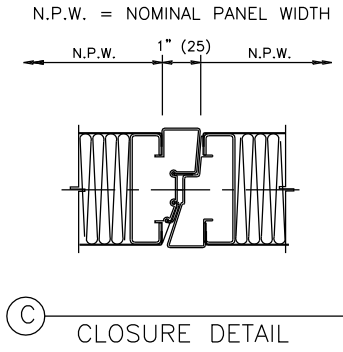
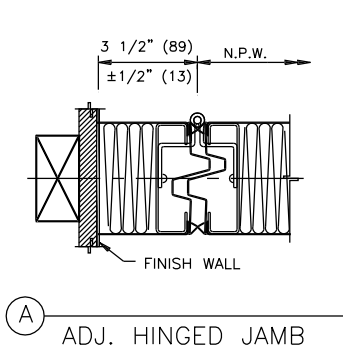

All dimensions shown in parentheses are millimeters. Scale: N.T.S.



Moduflex SERIES 800

Individual Panels Model 810 MD

VERTICAL SECTION - HEAD DETAILS - TYPE 9 ALUMINUM TRACK - HEIGHTS TO 16' (4877)

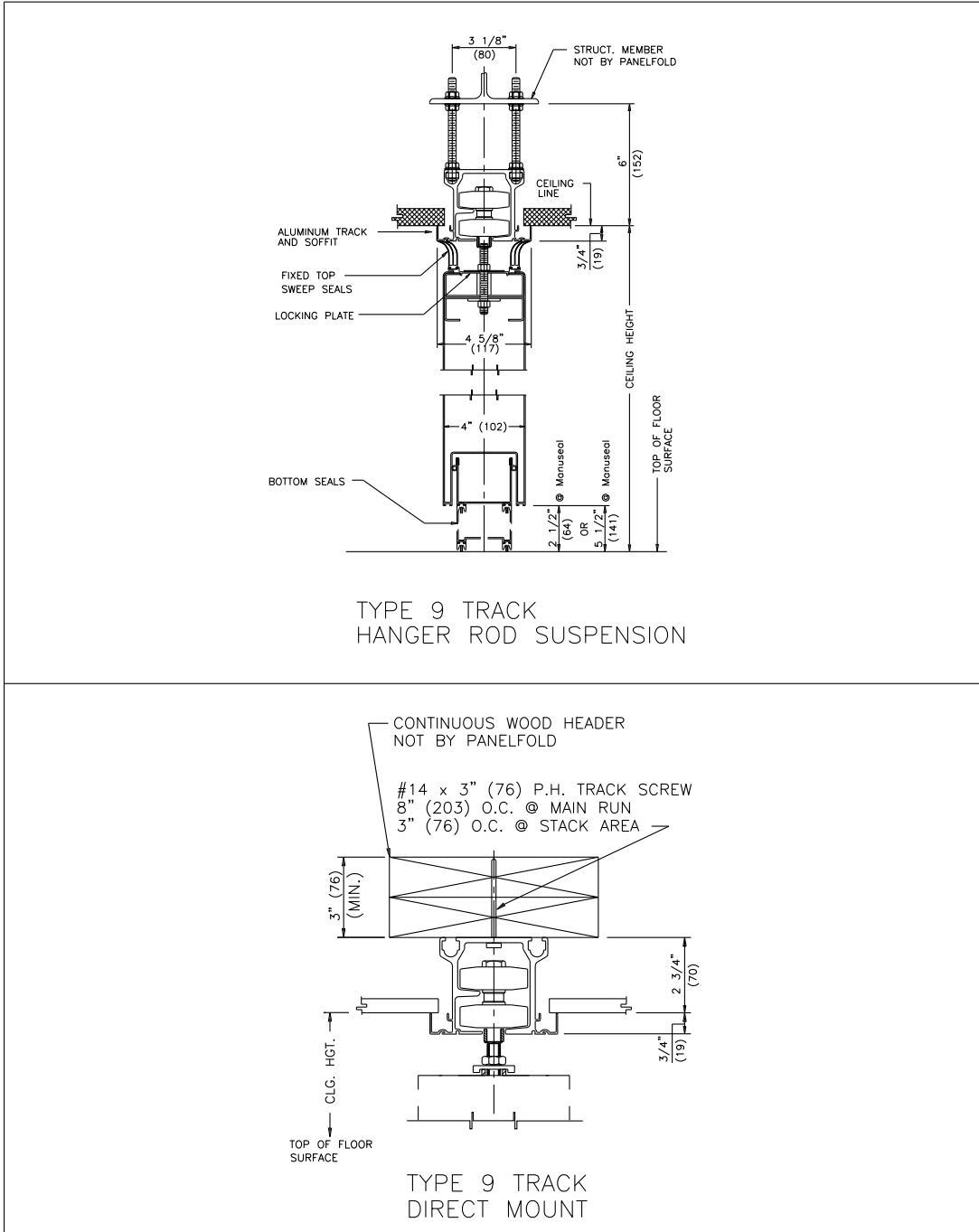

All dimensions shown in parentheses are millimeters. Scale: N.T.S.



Moduflex® SERIES 800
Individual Panels Model 810 MD

TYPE 9 ALUMINUM TRACK
PUNCHING TEMPLATE

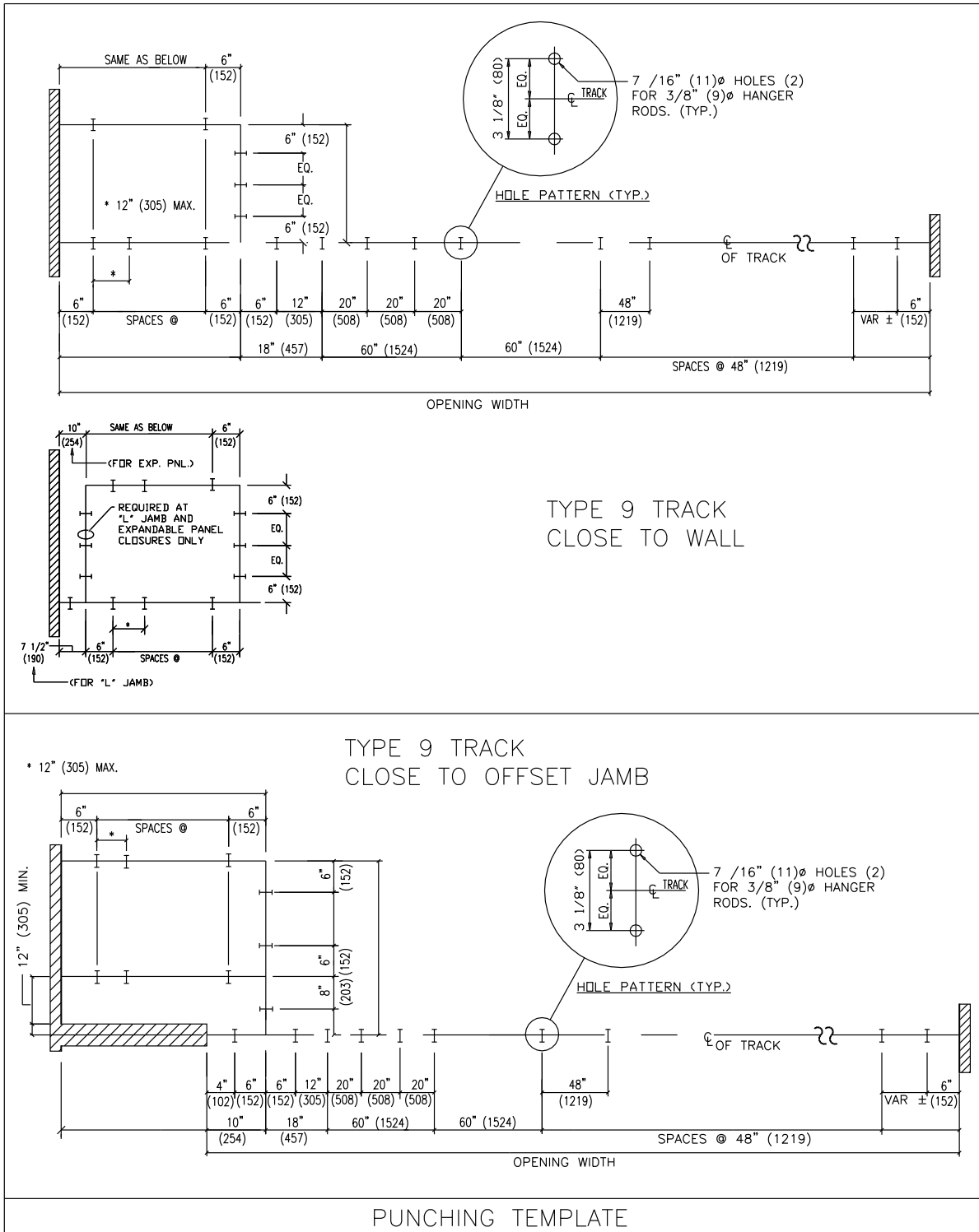

All dimensions shown in parentheses are millimeters. Scale: N.T.S.



Moduflex® SERIES 800

Individual Panels Model 810 MD

VERTICAL SECTION - HEAD DETAILS - TYPE 1 ALUMINUM TRACK - HEIGHTS TO 10'0" (3048)

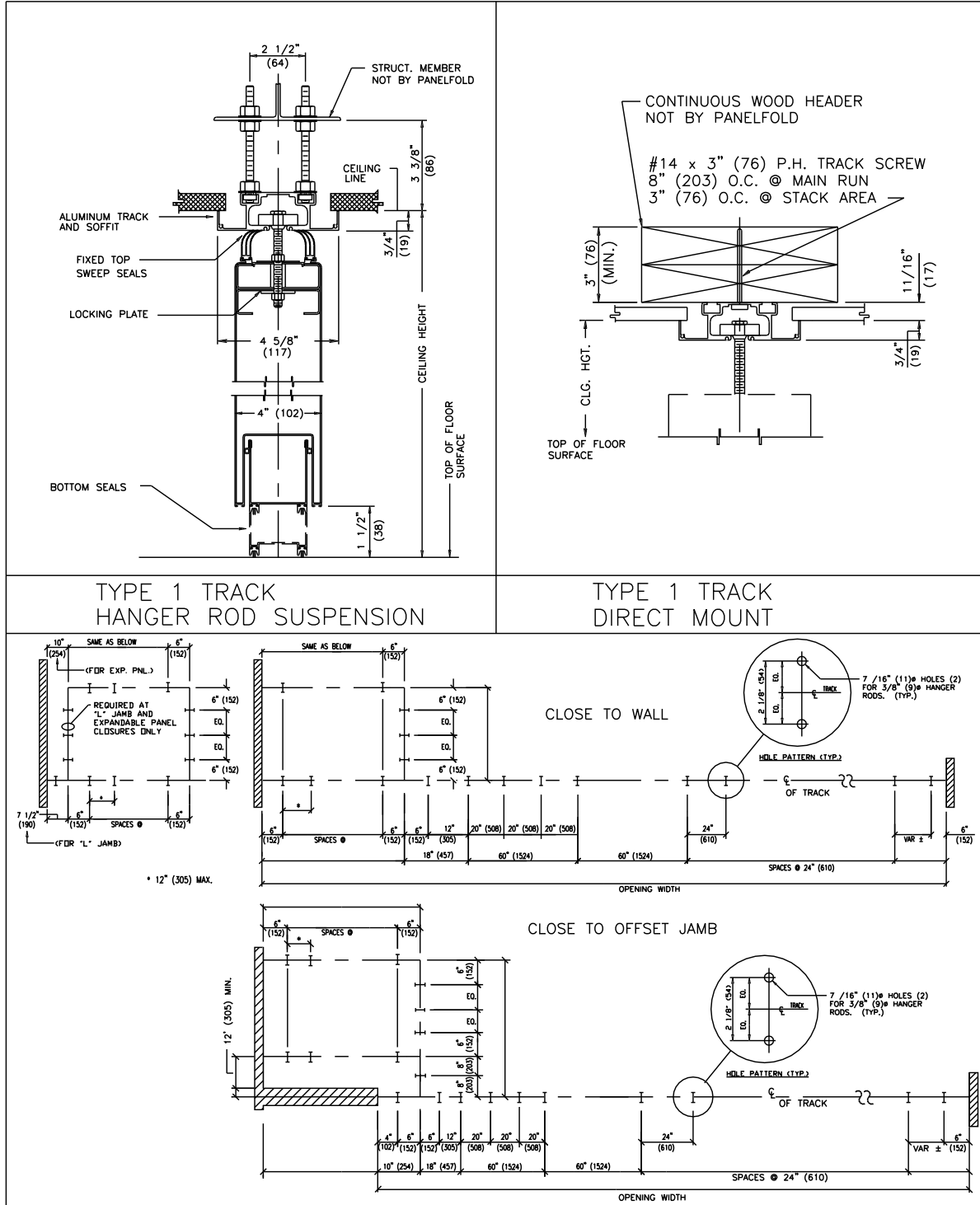

All dimensions shown in parentheses are millimeters. Scale: N.T.S.

Moduflex® SERIES 800

Individual Panels Model 810MD (Multi-Directional)

PRODUCT SPECIFICATIONS: SECTION 10650 - OPERABLE WALLS

PART 1 GENERAL

(See Project Guide Specifications for Scope, Related Work, References, Submittals, Product Delivery and Acceptable Manufacturers paragraphs.)

PART 2 PRODUCTS

2.1 OPERABLE WALLS shall be manufactured by Panelfold, Inc., Miami, Florida, U.S.A. and installed by an authorized representative of the manufacturer in openings prepared by others to Moduflex® Series 800 requirements.

2.2 OPERATION shall consist of a series of manually operated flat panels, top supported. Top and bottom seals shall be as specified in paragraph 2.9.

2.3 PANEL CONFIGURATION shall be as follows for areas indicated on the plans:

2.3.1 MODEL 810MD shall be comprised of a series of multi-directional individual panels, side or remote stacking (located in room(s)).

2.3.2 Final closure shall be effected by (specify: Jamb-Hinged single or bi-fold Panels; Expandable Panels; or Jamb-Hinged Communicating Panels).

2.4 PANELS shall be one-piece 4" (102) thick, all-steel construction. Continuous steel panel faces shall be invisibly welded to minimum 14 gauge (1.90) one-piece steel frames. Horizontal or vertical spliced frames or faces shall not be permitted. Interlocking vertical panel edges shall be made of steel.

The vertical edges of the panels shall not require trim thus minimizing the appearance of the vertical joining of the Sheer-Look® panels.

2.5 PANELS shall be factory surfaced with one of the following (colors to be selected from manufacturer's standards):

2.5.1 Manufacturer's standard vinyl, Class A flame spread (specify Type I; or Type II).

2.5.2 Manufacturer's standard Ribtex® Basic, vertical-rib wall carpeting, Class A.

2.5.3 Manufacturer's Woventex® panel fabric, Class A, acrylic latex backed.

2.5.4 Maharam Tekwall panel fabric, Class A, acrylic backed.

2.5.5 Customer's Own Material to be factory applied (subject to approval by the manufacturer for suitability to standard manufacturing processes and equipment).

2.5.6 Coated steel panel faces for field surfacing by others.

2.6 HANGING WEIGHT of panels shall not exceed 11.3 lbs/ft² (55 kg/m²).

2.7 ACOUSTICAL RATING as tested by an independent acoustical laboratory in accordance with

ASTM E90-81 test procedures in a full scale 14' 0" (4267) by 9' 3" (2819) opening shall be (specify: STC 55, STC 53, STC 51 or STC 49). Optional N.R.C. .80 STC 51.

2.8 ECHOSORB™ ACOUSTICAL WALL PANELS shall be provided where shown on the plans. Acoustical panels shall have obtained an NRC .75 rating per ASTM 423. Panels shall be provided with quick mounting and dis-mounting hardware requiring no tools. Acoustical transparent fabric to be selected from manufacturer's standards.

2.9 SOUND SEALS shall be as follows:

2.9.1 Vertical seals between panels shall consist of deep nesting, universal interlocking ESP bronze steel astragals incorporating continuous, vinyl acoustical seals. Vertical astragal vinyl seals shall be installed on the outboard edges of the panel skins in a double row with an acoustical labyrinth.

2.9.2 Horizontal TOP seals shall be (specify: continuous contact extruded vinyl shapes; or clearance type, automatically actuated; or clearance type, manually actuated).

2.9.3 Horizontal BOTTOM seals shall be 1 1/2" (38) clearance-type manually actuated at waist height on panel edges). Downward pressure of all clearance-type seal mechanisms shall assure an acoustical seal and resist panel movement.

2.10 SUSPENSION SYSTEM shall be heavy duty aluminum multi-directional (specify: type 1, or type 9) track. Track shall be supported by (specify: adjustable steel hanger rods; or direct mount). Each panel shall be supported by two carrier assemblies of (specify: glide discs, or dual horizontal rotating ball bearing wheels). Carrier assemblies shall be attached to the panels with adjustable steel pendant bolts with locks to prevent panel misalignment.

2.11 PANELS that are hinged together shall be hinged with manufacturer's standard butt-type hinges.

2.12 POCKET DOORS where indicated on the plans shall be manufactured of the same materials as the panels. Hinges shall be standard butt-type.

2.13 OPTIONAL U.L.® One Hour fire rated Firecoustic® models including full-thickness acoustical single and double pass doors, standard panel surfaces and intersecting walls shall be supplied where indicated on the plans.

PART 3 EXECUTION

(See Project Guide Specifications for Execution, Installation, Cleaning and Demonstration paragraphs).

NOTE: The ASTM - 84 procedure Class A flame spread and other test results referenced herein are for comparison purposes only and are not intended to reflect hazards presented by this or any other materials under actual fire conditions.

For further information, or additional technical information, contact your Panelfold distributor.

Panelfold®

FOLDING DOORS • ACOUSTICAL FOLDING PARTITIONS • ACOUSTICAL PANELS
OPERABLE WALLS • RELOCATABLE WALLS

Panelfold, Inc. P.O. Box 680130, Miami, Florida 33168
(305) 688-3501 • FAX: (305) 688-0185

Internet: www.panelfold.com • E-mail: sales@panelfold.com